

PVP2005-71333

ANALYTICAL RESEARCH ON MECHANISM OF BOLT LOOSENING DUE TO LATERAL LOADS

Yasumasa SHOJI
ABAQUS, Inc.
9-5-27 Akasaka, Minato-ku
Tokyo 107-0052, JAPAN
e-mail: yasumasa.shoji@abaqus.jp

Toshiyuki SAWA
Hiroshima University
Kagamiyama, Higashi-Hiroshima
Hiroshima 739-8527 JAPAN
sawa@mec.hiroshima-u.ac.jp

ABSTRACT

It is well known that bolted joints are loosened when lateral loads are applied after they are tightened. This phenomenon is proved by experiments or by the real operations, but the mechanism is not yet elucidated why the bolts are loosened. In this paper several finite element analyses were performed and reproduced the phenomenon that the bolts are loosened, or the nut rotates, when the lateral loads are applied. Based on this result, the mechanism of the bolt loosening (the nut rotation) is investigated. Additionally, it is also examined that bolts are more difficult to be loosened when double nut procedure is used or that they are almost not loosened when the eccentric bolt/nut systems are used. As the result, the bolt loosening is caused by the shape of the thread that is the wedge inclined to the bolt axis. When lateral loads are applied, the bolt/nut threads slide relatively, which causes the relative nut rotation. When the loads are released, the bolt returns to the normal position keeping the relative slide to the nut. This nut rotation causes a reduction of the bolt tension, too. Although the magnitude of this rotation may be quite small, many times of repetition makes the bolt loosened.

INTRODUCTION

It is well known that bolted joints are loosened when lateral loads are applied to the joint after they are tightened. This bolt loosening is observed in the site of plants quite frequently, and any joints are facing this risk at any sites. The practical (and only) countermeasure of the bolt loosening is to re-tighten them periodically to keep the required or desired bolt tension. As this re-tightening requires the periodic maintenance of the machinery, and as the number of the bolts is usually large, the maintenance cost becomes large and more maintenance personnel must be employed. Besides the cost, the period of the maintenance does not create any benefit, and this type of maintenance is strongly required to be eliminated or, at least, reduced as much as possible. Thus, if we can reduce or eliminate the bolt loosening, it will be very beneficial to the industry, to prevent the loss by the maintenance cost and the loss of possible benefit during the plant stops. This may be more beneficial to the society, as the useless energy loss of the

plants can be reduced which is not negligible at the start-up, shut-down or at the maintenance, and it results in the total higher efficiency of the energy consumption.

There are some researches [1], [2] which investigated this phenomenon, but the mechanism of the loosening is still unclear and the general countermeasures for the loosening are not achieved. Such measures as increasing pretension, double nut procedures, or lock wiring are used in practical situation but the effectiveness is not yet proved especially in the sites under quite severe vibrating conditions.

In this paper several finite element analyses were performed and reproduces the nut rotation. According to these results, the principal of the bolt loosening was investigated. Using the same method, it is found that normal bolt/nut system may become loose, but the market-sold eccentric bolt/nut systems[3] can prevent nut rotation that induces bolt loosening. ABAQUS (V6.4) was used for the finite element analyses.

ANALYTICAL METHOD

This section addresses the analytical model.

Analytical Object

The concept of the model is shown in Fig. 1, and the dimensions are indicated in Fig. 2. The size of the bolt is M8 that has the maximum dimensional tolerance of 0.014mm[4] in the radial direction. As the bolt thread slips most on the nut surface in the condition of maximum dimensional error, the analytical model employed this maximum allowable error.

Analytical Model

The analytical model is shown in Fig. 3. The finite element model has "modified" quadratic tetrahedral solid elements (C3D10M). This type of element is special for ABAQUS [5], and has high quality (accuracy). Although it is a quadratic solid elements, it can handle contact problems. The top portion of the bolt is defined as rigid body to maintain the circle shape during the loading, and is subjected to the radial motion. The whole nut portion is also meshed by C3D10M

elements and was defined as a rigid body after it is meshed. According to this modeling, the deformable part is only the bolt, and the calculation time can be reduced remarkably without losing generality. The friction between the threads of the bolt and the nut is taken into account, and the friction coefficient was assumed to be 0.1. This value is corresponding to the typical situation where the friction at bolt tightening is well controlled. The nut is constrained in all the degrees of freedom of translation and the rotation about all the axes except the bolt axis, so that only the rotation about the bolt axis is allowed. In this case, no inclination of the nut occurs, as it does not occur when the bolt joint fastens flat surfaces.

The pretension load of each bolt is applied using the special "bolt-pretension" capability of the program [5] and the bolt length is "fixed" after tightening so that the changes of the bolt-tension can be captured.

The material properties used in the analyses are as follows:

Young's Modulus, $E=190000\text{MPa}$

Poisson's Ratio, $\nu = 0.3$.

Analytical Cases

The following conditions were analyzed using the model shown in Fig. 3.

(1) Constraints (Boundary conditions)

The following cases (a) to (c) were considered to model different nut conditions:

- (a) Nut is allowed to rotate about its axis that is collocated to the bolt axis. Bolt top is allowed to move only in the radial (x-) direction. This is the case of "normal" situation.
- (b) Nut is allowed to rotate about its axis that is collocated to the bolt axis. Bolt top is allowed to move only in one radial (x-) direction, and the bottom is constrained not to move in the radial directions (x- and y-directions). This is the case of the first nut of "double nut" situation, or "constrained" situation.
- (c) After the pretension, nut is moved to the radial direction and in perpendicular to the bolt motion (z-direction) in order to "lock" the bolt by plunging nut thread into bolt thread. The nut radial movement is 0.025mm, while the gap is 0.014mm. After this radial movement, the nut motion is constrained to allow only the rotation about the axis. This is the situation of an eccentric bolt/nut system.

(2) Bolt Pretension

The following pretension loads were applied. The physical meanings of the loads are also described:

- (a) 500N: The case where the pretension is low to be almost loosened.
- (b) 1500N: The case where half of the desired tension is applied. This may take place when the tightening procedure is incorrect.
- (c) 3000N: The case where the desired bolt tension is applied. The average stress is approximately 100MPa.
- (d) 5000N: The case where the pretension is applied on the half way from the desired force to the force by the yield stress.
- (e) 8500N: The case where the bolt is tightened near to the yield stress.

(3) Displacement of the Bolt Top

The bolt top is subjected to two cycles of the following lateral displacement:

$$(+X \Rightarrow 0 \Rightarrow -X \Rightarrow 0 \Rightarrow +X \Rightarrow 0 \Rightarrow -X \Rightarrow 0)$$

(a) 0.01mm

(b) 0.02mm

These values are determined by the authors to examine the effect of the displacement relatively.

Among the cases above, the combination in which the analyses were carried out are indicated in Table 1.

Table 1 Analysis cases

ID No.	Bolt Type (Constraints)	Pretension [N]	Presc. Disp [mm]
1	Normal	500	0.01
2	Normal	1500	0.01
3	Normal	3000	0.01
4	Normal	5000	0.01
5	Normal	8500	0.01
6	Normal	500	0.02
7	Normal	1500	0.02
8	Constrained	500	0.01
9	Constrained	1500	0.01
10	Constrained	3000	0.01
11	Eccentric	500	0.01
12	Eccentric	1500	0.01
13	Eccentric	3000	0.01

ANALYTICAL RESULTS

The analytical results are discussed here.

Nut Rotation

The nut rotation angle is shown in Fig. 4 when the normal bolts are subjected to the pretension and to the bolt top displacement of 0.01mm (cases (1) – (5) of table 1). The figure shows that the nut rotation angles are different from each other depending on the pretension. The figure also shows that the nut angle reduces remarkably, if the tension is over 3000N. This means that the bolts are not loosened easily, if a certain preload is applied, or the bolts are tightened adequately.

Figure 5 indicates the time history of the nut rotation for the constrained bolt and eccentric bolt/nut system. For the case of the eccentric nut, the rotation angle itself is larger than the other conditions, but the direction is reversed when the load (or displacement) is reversed, so that the angular displacement recovers and returns to the original angle. In both the figures, the first and second cycles may show different behavior. Figure 6 summarizes the nut angle results of all the cases. In the figure, "(ave)" means the averaged value of the two cycles, and "(last)" means the results of only the second cycles. It is observed that the rotation angles change drastically at a certain pretension. It shows both the angles of the averages of the two cycles and the second cycle only. As learned from the Figures 4 and 5, the first cycle and the second cycle may behave differently. This fact is considered in Fig.6. The values are different, as expected, but the tendency of these plots is the

same. We can estimate the nut rotation, or bolt loosening, by the average or by solely the second cycles. The bolt tension clearly has significant effect to the bolt loosening.

Bolt Tension Changes

In the previous section, the nut rotation results were addressed. In this section the changes of the bolt tension during the nut rotation is discussed. Figure 7 shows the time history of the tension for normal bolts and Fig. 8 shows the cases of constrained nuts and eccentric nuts. The bolt tension is reduced in the case where the bolt is loosened, and this tension reduction causes the bolt to become looser. On the contrary, the tension is maintained for the bolt that is not loosened. For the eccentric system, the nut threads are plunged into the bolt threads and at this time bolt tension increases. According to the previous observation, this increased tension will tighten the bolt more and will make the bolt difficult to be loosened.

Frictional Force (Shear Stress) on the Contact Surfaces of Threads

The shear stresses in the transverse direction to the bolt axis are plotted in Fig. 9 to 11. Figure 9 is the case when the pretension of 1500N is applied to the normal bolt (case i, hereafter). Figure 10 is the case of 8500N for the normal bolt (case ii), and Fig.11 is the case when the eccentric nut is subjected to the pretension of 1500N (case iii). The bolt-top displacement is all 0.01mm, and each figure has three situations. They are in the second cycle and (a) when the bolt is displaced in X-direction, (b) when the bolt returns to the original position, and (c) when the bolt is displaced in -X-direction.

These figures show that the frictional stress alternates in the case where the bolt tends to be loosened (case i), while the frictional stress is kept mostly constant for the bolts which is hard to become loose by either the forces due to pretension (case ii) or eccentric nut plunging (case iii).

MECHANISM OF THE BOLT LOOSENING

In the previous section it was discussed that the shear stress, or frictional stress alternates in case i. This phenomenon of stress alternation is considered to be the cause of bolt loosening, or nut rotation. In the same section it was also pointed out that, for case ii and case iii, alternating stress is observed but quite small relative to the other frictional stresses which prevent nut rotation. In case ii, the nut rotation resistance is the frictional stress due to the bolt pretension. In case iii, the resistance is mainly the frictional stress due to the nut lateral displacement and additional friction occurs due to the increase of the bolt tension at the nut lateral displacement. In this case the frictional stress which causes the nut rotation is not large enough.

If we examine the phenomena, as indicated in Fig 12, the bolt threads plunge into nut thread when it is displaced laterally. At this time, the stress that is normal to the thread surface occurs. As the threads are inclined to the bolt axis, this stress has the components both of the stress along to the bolt axis and the stress perpendicular to the bolt axis. The stress along to the bolt axis increases the bolt tension and the

perpendicular stress generates the torque to the nut. When we see this perpendicular stress in more detail, this has the component of the stress tangential to the thread surface. The tangential stress causes the relative slide between the threads. If the bolt and nut threads slide relatively when the bolt moves laterally, and if it does not slide back when the bolt comes to the normal position, the slide is not recovered in the cycle. If this phenomenon happens repeatedly, the nut rotation will be accumulated to be large enough to induce bolt loosening, even though the rotation at one cycle is small. As we discussed in the previous sections, in case i, or in the case where the bolt loosened, this situation is true and the nut rotation was observed as indicated in Fig. 4, while in cases ii the alternating stress is observed but the amount is quite small. This means that more repetitions are necessary for the bolt to become loose in case ii. It will, however, become loose after many cycles.

On the other hand, in case iii, the alternating stress is not observed, as the bolt threads are "fixed" on the nut thread surfaces. When we see the nut rotation (Fig. 5), the rotation angle is larger than in the other cases, but the nut rotates reversely when the load is reversed, and it recovers when the bolt comes to the original position. This recoverable behavior at one cycle does not cause the accumulation of the nut rotation, and this means that the bolt does not become loose.

CONCLUSIONS

It is understood that the bolt loosening is induced by the alternating shear stress. This is caused by the wedge shape of the bolt and nut threads, and the alternating relative motion of these parts induces the nut rotation. When the bolt is subjected to larger pretension, the relative alternating shear stress becomes smaller. This makes that a bolt is harder to be loosened when the bolt tension is high enough.

When the bolt end of nut side is constrained not to move laterally, bolt is harder to be loosened and this may be the reason that double nut procedure works to reduce the bolt loosening

If the nut is set eccentrically relative to the bolt axis after the tightening process, the frictional stress to prevent the nut rotation is additionally generated and the bolt tension is increased. This shear stress deletes the alternating shear stress and prevents the bolt loosening.

REFERENCES

- [1] Zhang M. and Jiang Y., 2004, "Finite Element Modeling of Self-Loosening of Bolted Joints," Proceedings of PVP2004 Vol. 478, pp.19-27
- [2] Zhang M. and Jiang Y., 2004, "An Experimental Investigation of the Effects of Clamped Length and Loading Direction of Self-Loosening of Bolted Joints," Proceedings of PVP2004 Vol. 478, pp.129-136
- [3] Brochure of HARD LOCK Industry Co. Ltd, 2004, <http://www.hardlock.co.jp>
- [4] Japan Industrial Standards, JIS A0001
- [5] ABAQUS Analysis User's Manual V6.4, 2004

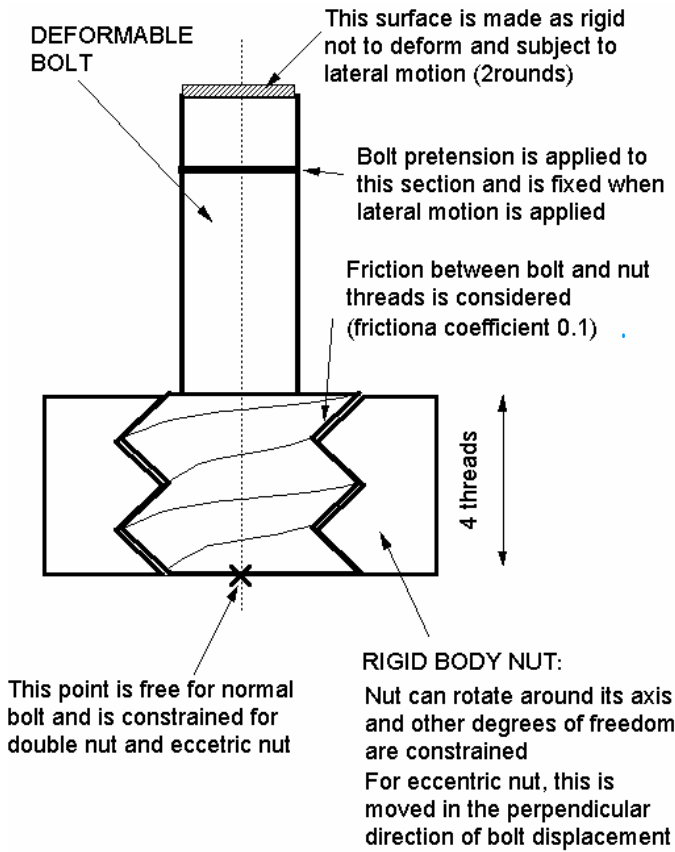

Fig. 1 Analytical Model Concept

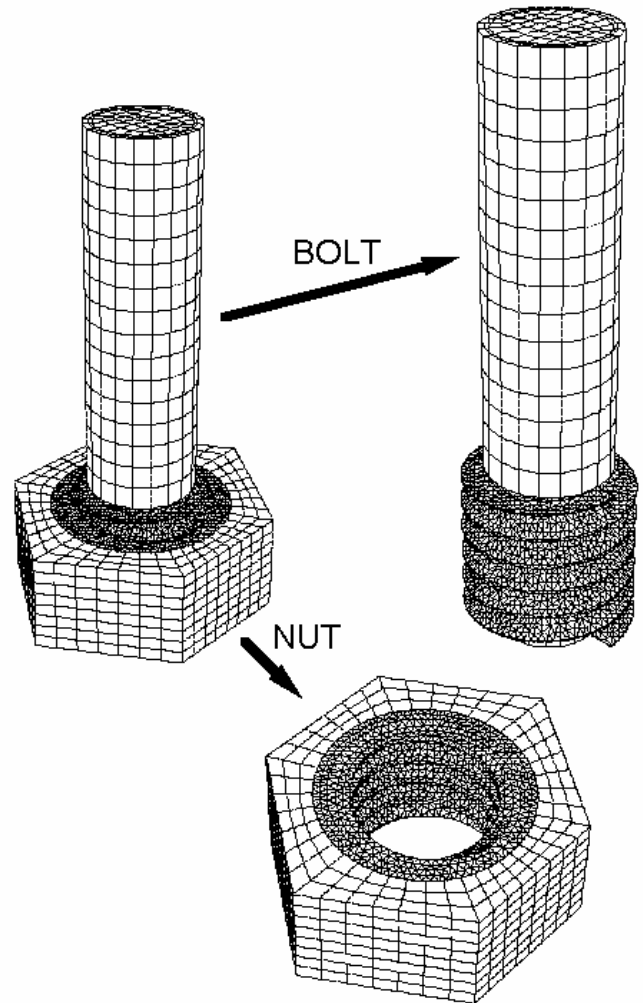

Fig. 3 Finite Element Model

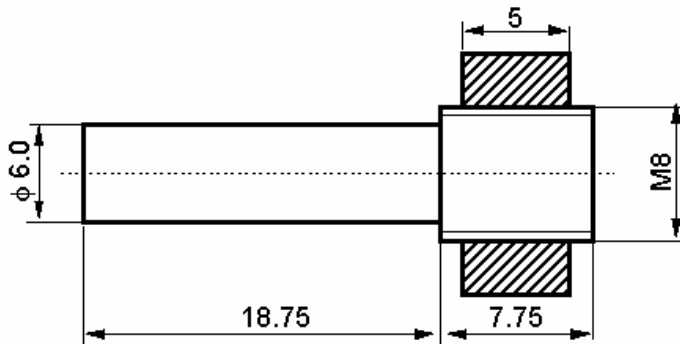

Fig. 2 M8 Bolt Dimensions

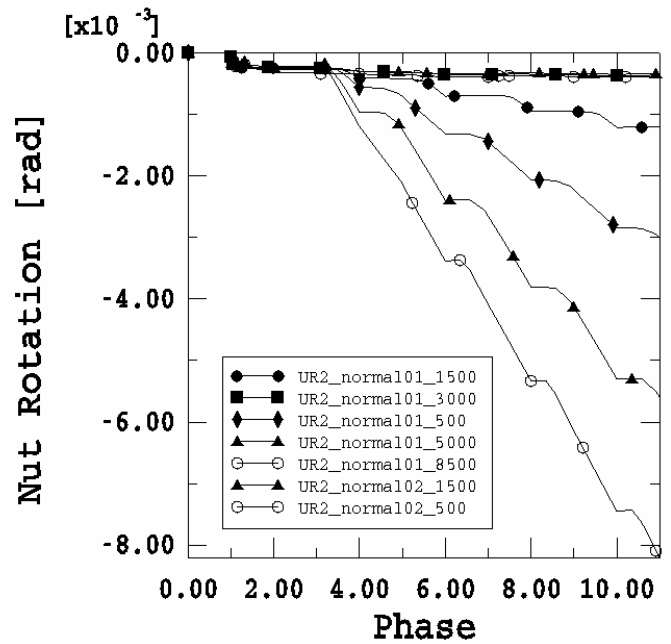

Fig. 4 Nut Rotation of "Normal" bolts (Bolt prescribed displacement 0.01 and 0.02mm)

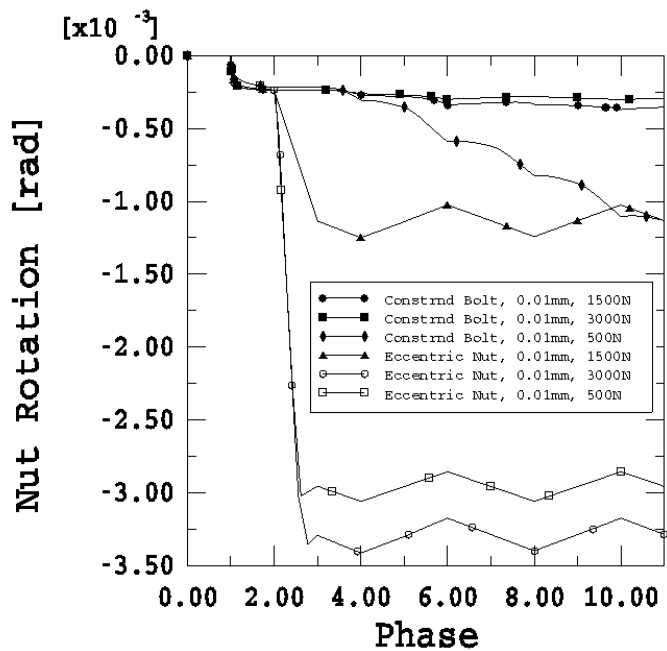

Fig. 5 Nut Rotation of Constrained and Eccentric bolts (Bolt prescribed displacement 0.01mm)

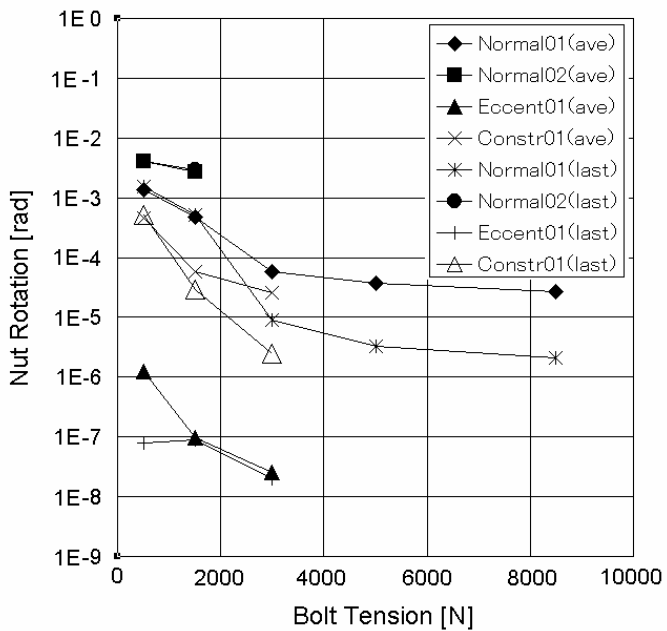

Fig. 6 Nut Rotation Summary --- Angle vs Tension

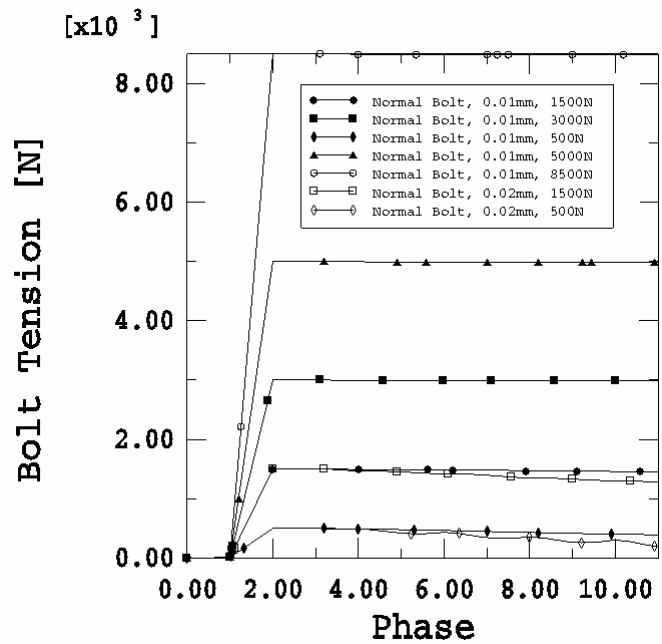

Fig. 7 Tension Changes of "Normal" Bolts

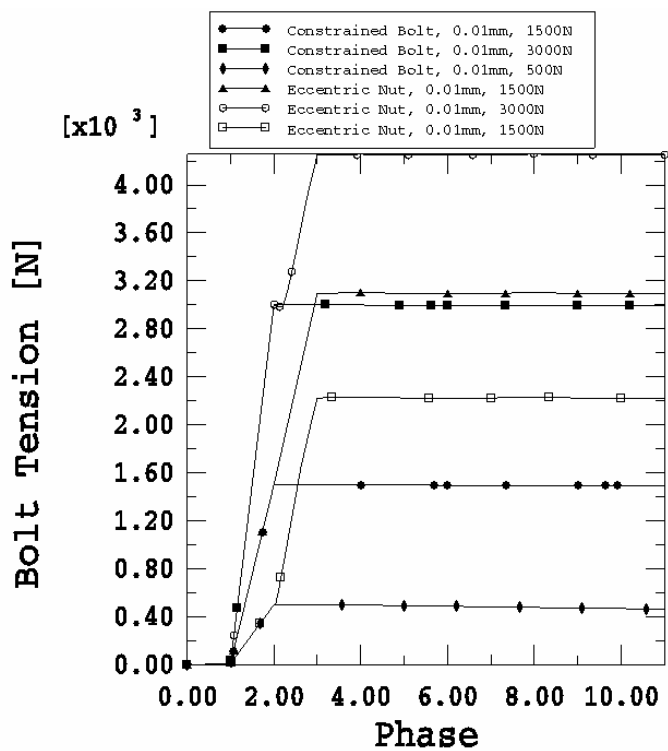

Fig. 8 Tension Changes of Constrained and Eccentric Bolts

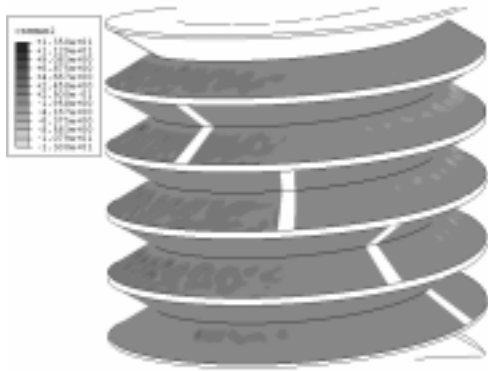

Fig. 9(a) Shear Stress on Bolt Thread at X-disp of Bolt (1500N pretension for “normal” bolt)

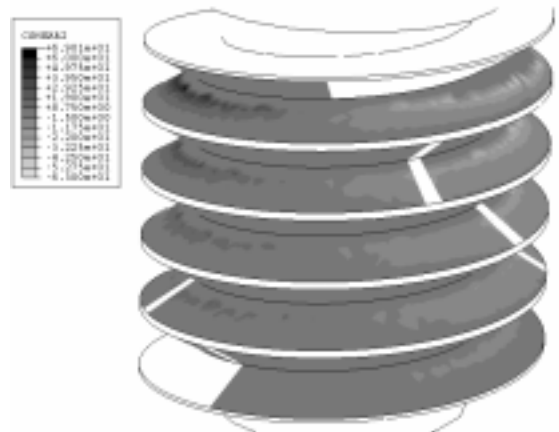

Fig. 10(a) Shear Stress on Bolt Thread at X-disp of Bolt (8500N pretension for “normal” bolt)

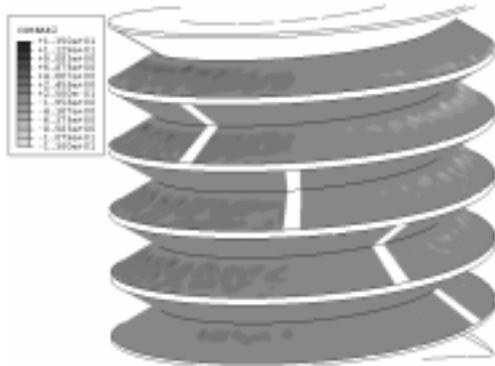

Fig. 9(b) Shear Stress on Bolt Thread at neutral position of Bolt (1500N pretension for “normal” bolt)

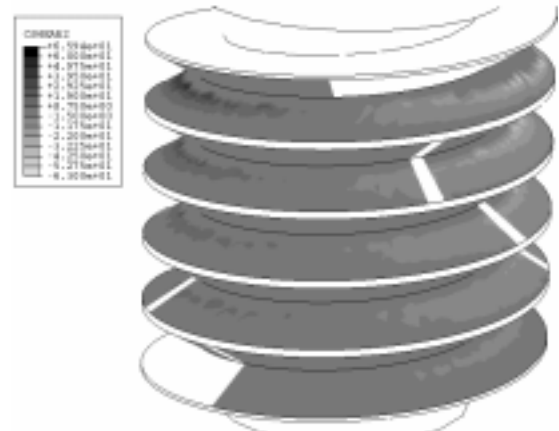

Fig. 10(b) Shear Stress on Bolt Thread at neutral posi of Bolt (8500N pretension for “normal” bolt)

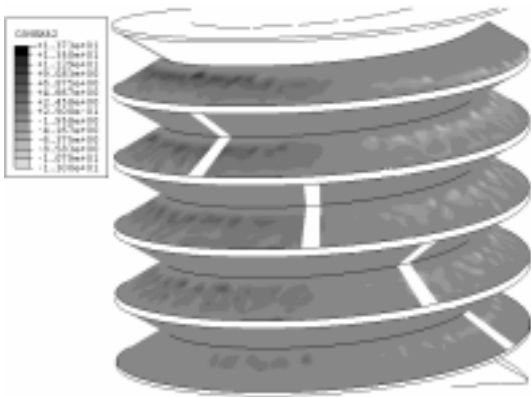

Fig. 9(c) Shear Stress on Bolt Thread at -X-disp of Bolt (1500N pretension for “normal” bolt)

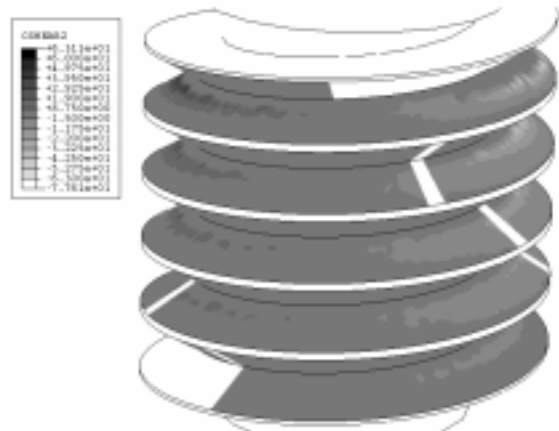

Fig. 10(c) Shear Stress on Bolt Thread at -X-disp of Bolt (8500N pretension for “normal” bolt)

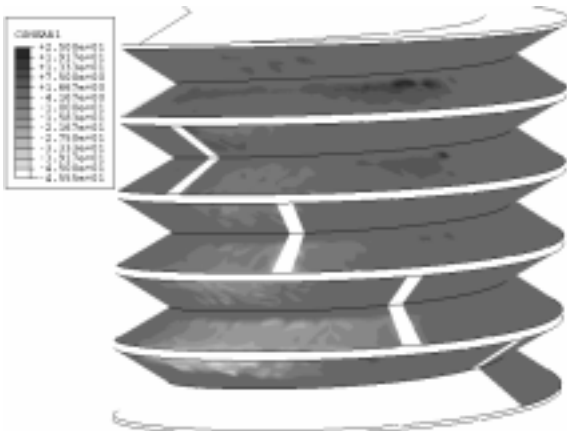

Fig. 11(a) Shear Stress on Bolt Thread at X-disp of Bolt (1500N pretension for eccentric bolt)

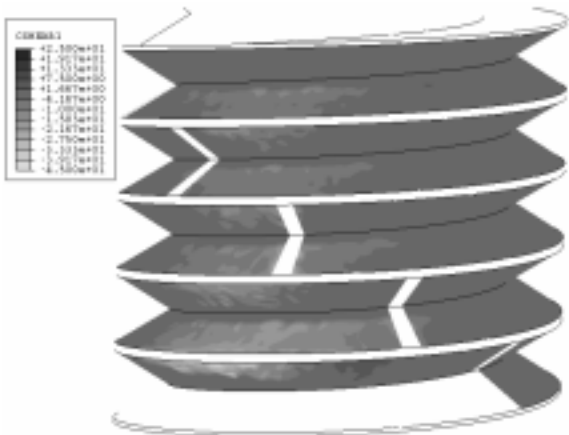

Fig. 11(b) Shear Stress on Bolt Thread at Neutral Disp of Bolt (1500N pretension for eccentric bolt)

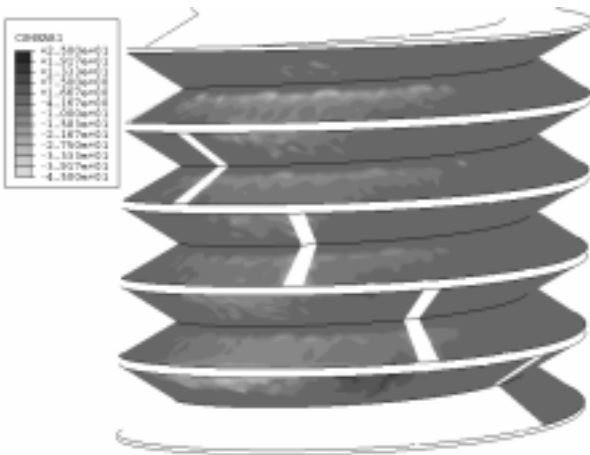
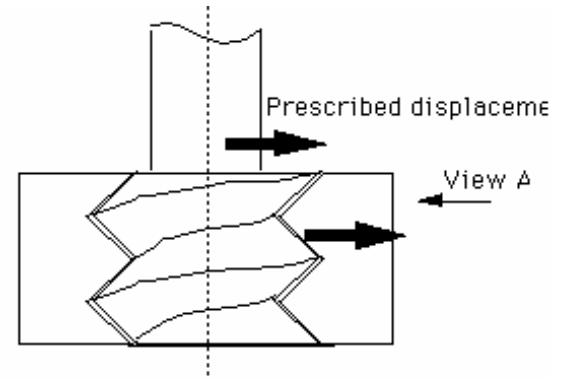
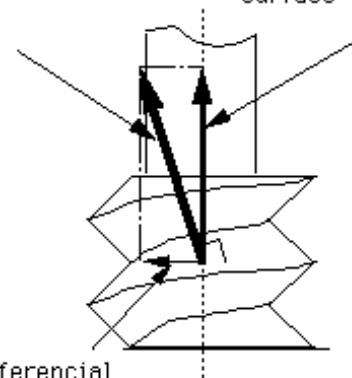

Fig. 11(c) Shear Stress on Bolt Thread at -X-disp of Bolt (1500N pretension for eccentric bolt)



F_{wedge} : Normal force on the surface, when the wedge (bolt) plunges into the nut

Axial component of F_{wedge} to push nut surface



Circumferential component of F_{wedge} to rotate nut

Force component from View

Fig. 12 The mechanism of the nut rotation